



# Zhangjiagang Jiekang Medical Products

Jiekang Medical Equipment

---

Name : Carlos

Phone : +8619941913491

2022.05.04

## About Us



## Company Profile

OUR COMPANY

We are a professional manufacturer of first aid products in China. We specialize in manufacturing a wide range of stretchers, splints, hospital beds, resuscitation beds, water and other life-saving supplies. Our product range is over 300 kinds. We export our products to 49 countries and regions. We have about 1500 customers all over the world. We have an excellent sales team, production team and R&D team. We are the rescue experts around you.



# Company Philosophy



## Values

Love, Dedication, Integrity and Commitment

## Corporate Vision

Create the first brand in the first aid industry

## Corporate Mission

The most professional way to save lives at risk

# Catalog

## Stretcher

1. [Neil-Roberto](#)
2. [Spinal board](#)
3. [Aluminum Alloy Folding Stretcher](#)
4. [Aluminum Alloy Ambulance Stretcher](#)
5. [Scoop Stretcher](#)
6. [Basket Stretcher](#)
7. [Stair Stretcher](#)
8. [Multifunctional Rescue Stretcher](#)
9. [Vacuum Mattress Stretcher](#)

# Neil-Robertro

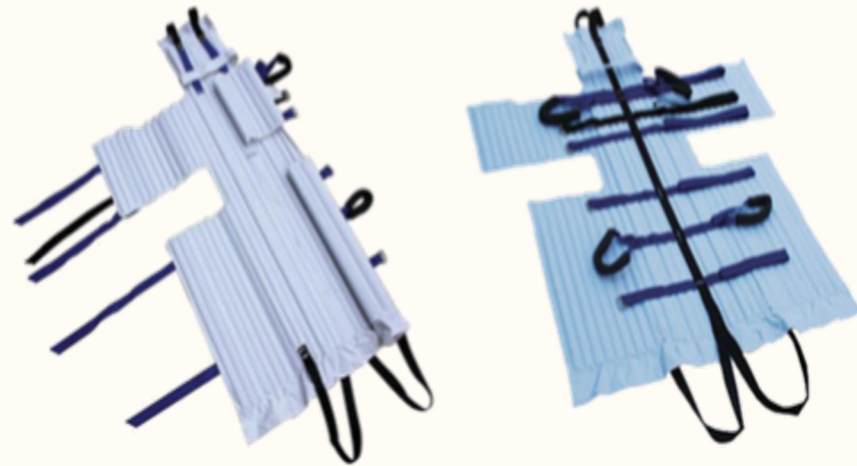

This product is called Robertson stretcher, marine stretcher, marine canvas stretcher, etc.

It is suitable for all kinds of ships, field work, mining, construction industry, etc.

It meets the requirements of "Robertson Stretcher" which is recommended in the normative blueprint of "International Ship Medical Guide" compiled by the World Health Organization (WTO) to adapt to the characteristics of ships.

The liner is made of hardwood and the fabric is canvas with good anti-slip surface. Multiple safety straps ensure load-bearing and safety when placed horizontally and vertically.

Effective protection of the casualty's spine. Easy to fold, easy to store.

Product	Model	N.W.	G.W.	Fabric	Horizontal safe load	Vertical safe load	Packaging Information	
Neil-Boberthro	YJK-N -7	6.45KG	7.25KG	Canvas	120KG	120KG	1PC/CTN	153×17×16.5CM

[Back to the catalog](#)

# Spinal board



This product is also known as spinal board, lifting board, board stretcher, plastic stretcher, fixed lifting board, floating rescue board, spinal board stretcher, etc.

This product is made of high-density plastic polyethylene blow molding, strong and durable, not easy to aging. This product is suitable for all kinds of harsh environment rescue, strong anti-collision performance, waterproof and easy to clean.

Can be X-ray, MRI, CT penetration effect is excellent, convenient for the injured to check, minimize the pain caused to the patient in the process of transport.

Uniform opening of the periphery of the hand opening, can be carried by multiple people at the same time, carrying, lifting. Hard structure, easy to continue CPR and cardiac compression during the transfer process, large drainage capacity, the overall volume of 0.04m<sup>3</sup>, in room temperature water can float an adult, greatly reducing the difficulty of water lifesaving personnel, to facilitate faster rescue of the injured.

Spinal fixation set contains a neck brace, head fixator and spinal fixation plate, this product is generally equipped with three straps.

Product	Model	Open Size	Loading	N.W.	G.W.	Packing Size	
Spinal board	YJK-F1	183×45×6CM	≤159KG	7KG	9KG	1PC/CTN	184×46×7CM

# Spinal board



This product is also known as spinal board, lifting board, board stretcher, plastic stretcher, fixed lifting board, floating rescue board, spinal board stretcher, etc.

This product is made of high-density plastic polyethylene blow molding, strong and durable, not easy to aging. This product is suitable for all kinds of harsh environment rescue, strong anti-collision performance, waterproof and easy to clean.

Can be X-ray, MRI, CT penetration effect is excellent, convenient for the injured to check, minimize the pain caused to the patient in the process of transport. Uniform opening of the periphery of the hand opening, can be carried by multiple people at the same time, carrying, lifting. Hard structure, easy to continue CPR and cardiac compression during the transfer process, large drainage capacity, the overall volume of 0.04m<sup>3</sup>, in room temperature water can float an adult, greatly reducing the difficulty of water lifesaving personnel, to facilitate faster rescue of the injured.

Spinal fixation set contains a neck brace, head fixator and spinal fixation plate, this product is generally equipped with three straps.

Product	Model	Open Size	Loading	N.W.	G.W.	Packing Size	
Spinal board	YJK-F2	184×45×6.5CM	≤159KG	7.5KG	9KG	1PC/CTN	185×47.5×7CM

# Spinal board

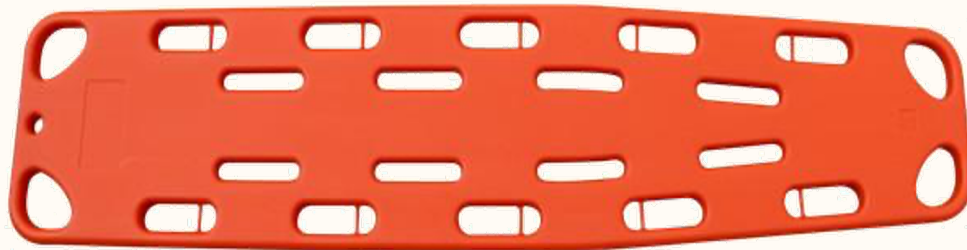

This product is also known as spinal board, lifting board, board stretcher, plastic stretcher, fixed lifting board, floating rescue board, spinal board stretcher, etc.

This product is made of high-density plastic polyethylene blow molding, strong and durable, not easy to aging. Suitable for all kinds of harsh environment rescue, strong anti-collision performance, waterproof and easy to clean.

Can be X-ray, MRI, CT penetration effect is excellent, convenient for the injured to check, minimize the pain caused to the patient in the process of transport.

Uniform opening of the periphery of the hand opening, can be carried by multiple people at the same time, carrying, lifting. Hard structure, easy to continue CPR and cardiac compression during the transfer process, large drainage capacity, the overall volume of 0.04m<sup>3</sup>, in room temperature water can float an adult, greatly reducing the difficulty of water lifesaving personnel, to facilitate faster rescue of the injured.

Spinal fixation set contains a neck brace, head fixator and spinal fixation plate, this product is generally equipped with three straps.

Product	Model	Open Size	Loading	N.W.	G.W.	Packing Size	
Spinal board	YJK-F3	186×41×5CM	≤159KG	6.5KG	8.5KG	1PC/CTN	187×43×7CM



# Spinal board

 YJK-F4

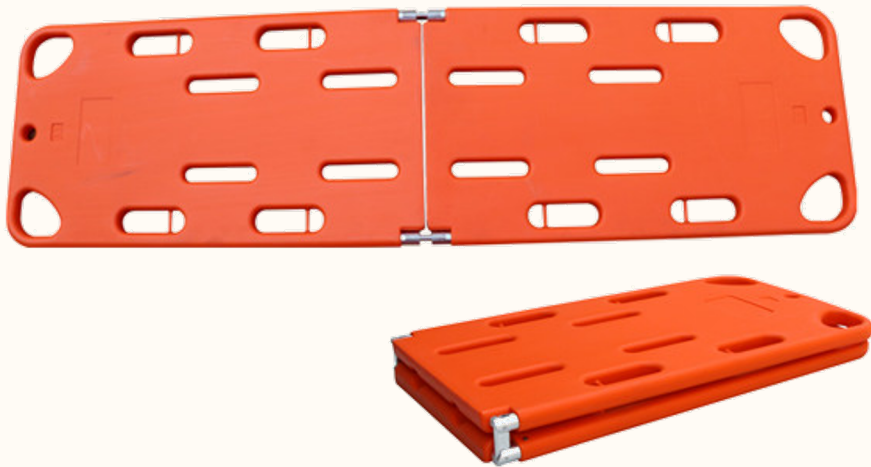

This product is also known as spinal board, folding spinal board, carrying board, board stretcher, plastic stretcher, fixed carrying board, etc.

This product is made of aluminum tube and high-density plastic polyethylene blow molding, strong and durable, not easy to aging. Suitable for all kinds of harsh environment rescue, strong anti-collision performance, waterproof and easy to clean.

Can be X-ray, MRI, CT penetration effect is excellent, convenient for the injured to check, minimize the pain caused to the patient in the process of transport.

Uniform opening of the periphery of the hand opening, can be carried by multiple people at the same time, carrying, lifting. The rigid structure facilitates CPR and cardiac compressions during the transfer process.

The spinal fixation set contains a neck brace, head fixator and spinal fixation plate, and this product is generally equipped with three straps.

Product	Model	Open Size	Loading	N.W.	G.W.	Packing Size	
Spinal board	YJK-F4	187×50×4CM	≤159KG	8.8KG	10KG	1PC/CTN	97×56×10CM

[Back to the catalog](#)

# Spinal board

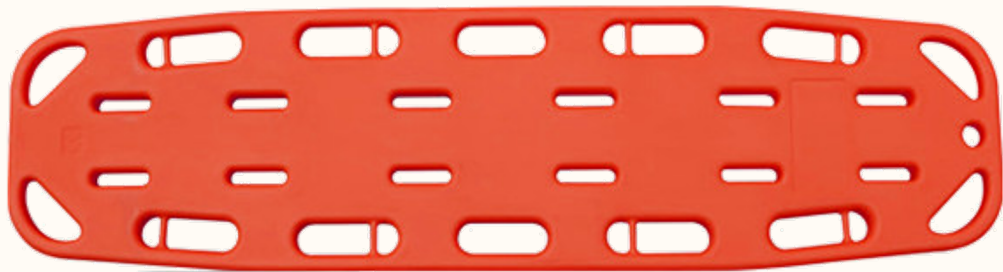

This product is also known as spinal board, lifting board, board stretcher, plastic stretcher, fixed lifting board, floating rescue board, spinal board stretcher, etc.

This product is made of high-density plastic polyethylene blow molding, strong and durable, not easy to aging. Suitable for all kinds of harsh environment rescue, strong anti-collision performance, waterproof and easy to clean.

Can be X-ray, MRI, CT penetration effect is excellent, convenient for the injured to check, minimize the pain caused to the patient in the process of transport.

Uniform opening of the periphery of the hand opening, can be carried by multiple people at the same time, carrying, lifting. Hard structure, easy to continue CPR and cardiac compression during the transfer process, large drainage capacity, the overall volume of 0.04m<sup>3</sup>, in room temperature water can float an adult, greatly reducing the difficulty of water lifesaving personnel, to facilitate faster rescue of the injured.

Spinal fixation set contains a neck brace, head fixator and spinal fixation plate, this product is generally equipped with three straps.

Product	Model	Open Size	Loading	N.W.	G.W.	Packing Size	
Spinal board	YJK-F6	138×35×5CM	≤159KG	3.8KG	4.9KG	1PC/CTN	143×36×7CM

# Spinal board



YJK-F8

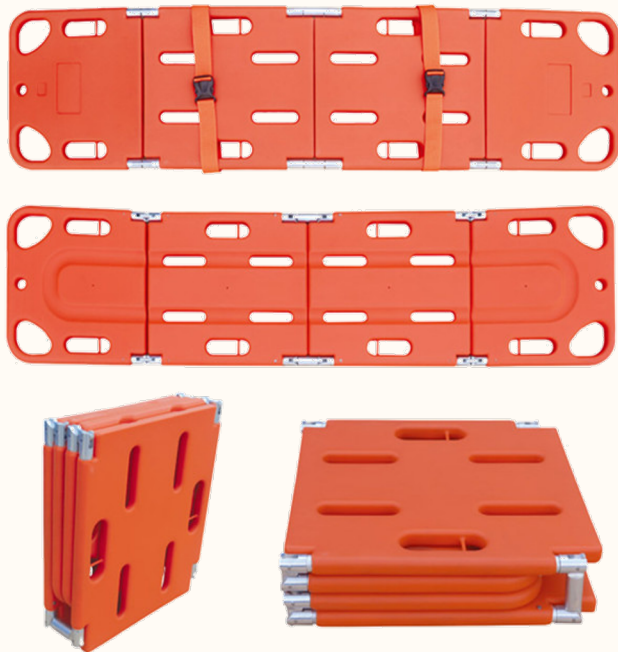

This product is also known as spinal board, folding spinal board, carrying board, board stretcher, plastic stretcher, fixed carrying board, etc.

This product is made of aluminum tube and high-density plastic polyethylene blow molding, strong and durable, not easy to aging.

This product is suitable for various harsh environment rescue, strong anti-collision performance, waterproof and easy to clean. It can be X-ray, MRI, CT penetration effect is excellent, convenient for the injured to check, minimize the pain caused to the patient in the process of transport.

Uniform opening of the periphery of the hand opening, can be carried by multiple people at the same time, carrying, lifting. The rigid structure facilitates CPR and cardiac compressions during the transfer process.

The spinal fixation set contains a neck brace, head fixator and spinal fixation plate, and this product is generally equipped with three straps.

Product	Model	Open Size	Loading	N.W.	G.W.	Packing Size	
Spinal board	YJK-F8	191×47×3CM	≤159KG	8.45KG	9.1KG	1PC/CTN	55.5×55.5×15.5CM

[Back to the catalog](#)

# Spinal board



YJK-F9

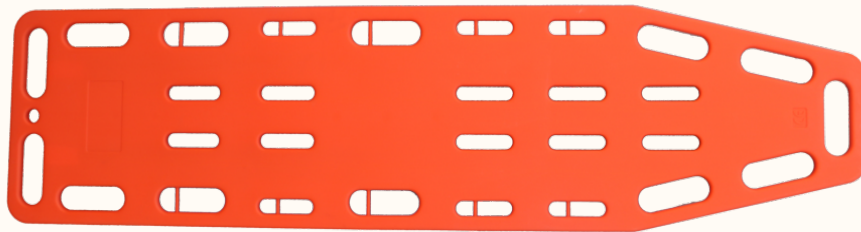

This product is also known as spinal board, folding spinal board, carrying board, board stretcher, plastic stretcher, fixed carrying board, etc.

This product is made of aluminum tube and high-density plastic polyethylene blow molding, strong and durable, not easy to aging. Suitable for all kinds of harsh environment rescue, strong anti-collision performance, waterproof and easy to clean.

Can be X-ray, MRI, CT penetration effect is excellent, convenient for the injured to check, minimize the pain caused to the patient in the process of transport. Uniform opening of the periphery of the hand opening, can be carried by multiple people at the same time, carrying, lifting.

The rigid structure facilitates CPR and cardiac compressions during the transfer process.

The spinal fixation set contains a neck brace, head fixator and spinal fixation plate, and this product is generally equipped with three straps.

Product	Model	Open Size	Loading	N.W.	G.W.	Packing Size	
Spinal board	YJK-F9	183×45×4.5CM	≤159KG	6.55KG	8.6KG	1PC/CTN	186×47×6CM

[Back to the catalog](#)

# Spinal board



YJK-F10



This product is also known as spinal board, folding spinal board, carrying board, board stretcher, plastic stretcher, fixed carrying board, etc.

This product is made of high-density plastic polyethylene blow molding, strong and durable, not easy to aging. Can be disassembled and used, contains an adult spinal board and a child spinal board. Suitable for all kinds of harsh environment rescue, strong anti-collision performance, waterproof and easy to clean.

Can be X-ray, MRI, CT penetration effect is excellent, convenient for the injured to check, minimize the pain caused to the patient in the handling process. Uniform opening of the periphery of the hand opening, can be carried by multiple people at the same time, carrying, lifting. The rigid structure is convenient for CPR and cardiac compressions during the transfer process.

The spinal board can be used with neck brace and head immobilizer, and the product is generally equipped with three straps.

Product	Model	Open Size	Loading	N.W.	G.W.	Packing Size	
Spinal board	YJK-F10	183×44.5×6CM	≤159KG	7.64KG	11.85KG	1PC/CTN	185×47.5×7CM
Spinal board	YJK-F10	120×32×4.5CM	≤159KG	2.51KG	3KG	1PC/CTN	122×33×5CM

[Back to the catalog](#)

# Spinal board



YJK-F13



This product is also known as spinal board, carrying board, board stretcher, plastic stretcher, fixed carrying board, floating rescue board, etc..

Made of high-strength engineering plastic, durable, not easy to aging, can safely transfer the sick and wounded, is a kind of first aid transfer equipment can be equipped to the medical sector, can be X-ray fluoroscopy, can be equipped with head fixation, can be equipped with straps, this product is generally equipped with four straps.

Product	Model	Open Size	Loading	N.W.	G.W.	Packing Size	
Spinal board	YJK-F13	201×51×7CM	≤159KG	11KG	12KG	1PC/CTN	201×52.5×7.5CM

[Back to the catalog](#)

# Wooden Stretcher



This product is also known as spinal board, carrying board, board stretcher, fixed carrying board, etc..

Made of high-density wood board, durable, not easy to aging, not bending, can safely transfer the sick and wounded, is a kind of first aid transfer equipment can be equipped to the medical sector, can be equipped with head immobilizer, can be equipped with straps, this product is generally equipped with four straps.

Product	Model	Open Size	Loading	N.W.	G.W.	Packing Size	
Wooden Stretcher	YJK-F14	197×51×5.5CM	≤159KG	10.6KG	12KG	1PCS/CTN	198×53×6CM

[Back to the catalog](#)

# Aluminum Alloy Folding Stretcher



YJK-A1-1



This product is also known as stretcher, folding stretcher, aluminum alloy stretcher, aluminum alloy folding stretcher, simple stretcher, etc. .

The frame part of this product is mainly made of high-strength aluminum alloy, with light weight, small volume, easy to carry, safe to use and other characteristics.

The surface of the stretcher is made of blue Oxford leather, which makes it more comfortable for the patient to lie down. With two wheels at one end and two support feet at the other end, the patient can be transferred by lifting one end of the support feet when there are not enough hands. Support feet and casters can be folded and stored, more convenient to use. This product is equipped with two safety straps to ensure the safety of the patient during transportation.

Mainly used in hospitals, outpatient departments, ambulances, firefighters and troops in the field to transport the sick and wounded or enterprises and institutions, rural health offices, homes for the elderly and tourist attractions equipped with emergency use.

Product	Model	Open Size	Fold Size	Loading	N.W.	G.W.	Packing Size	
Folding Stretcher	YJK-A1-1	185.5*52*22.2CM	92.4*52*10CM	≤159KG	5.4KG	6.4KG	1PC/CTN	98*54*10CM

[Back to the catalog](#)



# Aluminum Alloy Folding Stretcher



YJK-A3-1



This product is also known as stretcher, folding stretcher, aluminum alloy stretcher, aluminum alloy folding stretcher, simple stretcher, etc. .

The frame part of this product is mainly made of high-strength aluminum alloy, with light weight, small volume, easy to carry, safe to use and other characteristics.

The surface of the stretcher is made of blue Oxford leather, which makes it more comfortable for the patient to lie down. With backrest design, the angle of the backrest can be adjusted according to the comfort of the customer, making the patient more comfortable on the way to the doctor. With two wheels at one end and two support feet at the other end, the patient can be transferred by lifting one end of the support feet in case of insufficient manpower. The support feet and casters can be folded and stored, making it more convenient to use. This product is equipped with two safety straps to ensure the safety of the patient on the way to the doctor.

Mainly used in hospitals, outpatient departments, ambulances, firefighters and troops in the field to transport the sick and wounded or enterprises and institutions, rural health offices, homes for the elderly and tourist attractions equipped with emergency use.

Product	Model	Open Size	Fold Size	Loading	N.W.	G.W.	Packing Size	
Folding Stretcher	YJK-A3-1	185*50*24CM	92*51.5*11CM	≤159KG	6.39KG	7.66KG	1PC/CTN	96*54*10CM

[Back to the catalog](#)

# Aluminum Alloy Folding Stretcher

 YJK-A5-1



This product is also known as aluminum alloy stretcher, folding stretcher, aluminum alloy folding stretcher, etc..

Made of high-strength aluminum alloy and Oxford leather surface, it has the characteristics of light weight, small size, easy to carry, safe to use, etc. It is mainly used for funeral homes, crematoriums to transport the body.

Product	Model	Open Size	Fold Size	Loading	N.W.	G.W.	Packing Size	
Folding Stretcher	YJK-A5-1	185.5*52.5*21CM	98*54*20CM	≤159KG	7.2KG	8.39KG	1PC/CTN	96.5*55*12CM

[Back to the catalog](#)

# Aluminum Alloy Folding Stretcher



This product is also known as stretcher, folding stretcher, aluminum alloy stretcher, aluminum alloy folding stretcher, simple stretcher, etc. .

The frame part of this product is mainly made of high-strength aluminum alloy, with light weight, small volume, easy to carry, safe to use and other characteristics.

The surface of the stretcher is made of blue Oxford leather, which makes it more comfortable for the patient to lie down. This product is equipped with two safety straps to ensure the safety of the patient during transportation.

Mainly used in hospitals, outpatient departments, ambulances, firefighters and troops in the field to transport the sick and wounded or enterprises and institutions, rural health offices, homes for the elderly and tourist attractions equipped with emergency use.

Product	Model	Open Size	Fold Size	Loading	N.W.	G.W.	Packing Size	
Folding Stretcher	YJK-B1-1	185*50*3CM	92.5*50*7CM	≤159KG	8KG	9KG	2PC/CTN	96*54*18CM

[Back to the catalog](#)

# Aluminum Alloy Folding Stretcher



YJK-B2-1

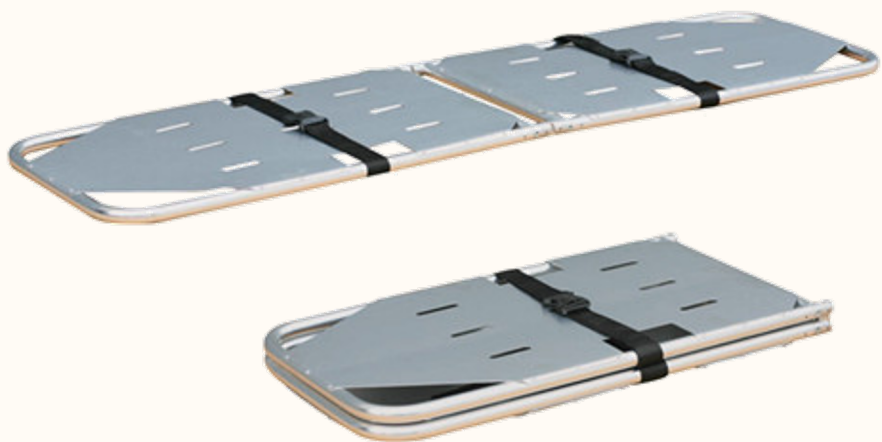

This product is also known as stretcher, folding stretcher, aluminum alloy stretcher, aluminum alloy folding stretcher, simple stretcher, etc. .

The frame part of this product is mainly made of high-strength aluminum alloy, with light weight, small size, easy to carry, safe to use and other characteristics.

The stretcher surface is made of aluminum alloy plate, which is convenient for fracture patients to use and avoid secondary injuries on the way to the hospital.

This product stretcher surface with hollow design is more breathable, cleaning is also extremely convenient. This product is equipped with two safety straps to ensure the safety of patients in transit.

Mainly used in hospitals, outpatient clinics, ambulances, firefighters and troops in the field to transport the sick and wounded or enterprises and institutions, rural health offices, homes for the elderly and tourist attractions equipped with emergency use.

Product	Model	Open Size	Fold Size	Loading	N.W.	G.W.	Packing Size	
Folding Stretcher	YJK-B2-1	185*50*3CM	92.5*50*7CM	≤159KG	14.66KG	15.90KG	2PC/CTN	94*54*16CM

[Back to the catalog](#)

# Aluminum Alloy Folding Stretcher



YJK-B3-1



This product is also known as stretcher, folding stretcher, simple stretcher, etc..

The frame part of this product is mainly made of steel pipe material, with light weight, small volume, easy to carry, safe to use and other characteristics.

The surface of the stretcher is made of blue Oxford leather, which makes it more comfortable for the patient to lie down. This product is equipped with two safety straps to ensure the safety of the patient during transportation.

Mainly used in hospitals, outpatient departments, ambulances, firefighters and troops in the field to transport the sick and wounded or enterprises and institutions, rural health offices, homes for the elderly and tourist attractions equipped with emergency use.

Product	Model	Open Size	Fold Size	Loading	N.W.	G.W.	Packing Size	
Folding Stretcher	YJK-B3-1	185.6*51.4*3.1CM	92.5*51.4*10CM	≤159KG	12.48KG	13.85KG	2PC/CTN	98.5*56.3*18CM

[Back to the catalog](#)

# Aluminum Alloy Folding Stretcher



This product is also known as stretcher, aluminum alloy stretcher, fire stretcher, rescue stretcher, etc.

This product is not foldable, the frame part is mainly made of high strength aluminum alloy. The stretcher surface is made of camouflage oxford leather surface with pillowcase, which makes the patient more comfortable to lie down. With four support feet, the patient can be rescued in uneven ground.

This product handle has a telescopic function, convenient to close the storage, reduce the length. This product is equipped with two safety straps to ensure the safety of patients in transit.

Mainly used in hospitals, outpatient departments, ambulances, firefighters and troops in the field to transport the sick and wounded or enterprises and institutions, rural health offices, homes for the elderly and tourist attractions equipped for emergency use.

Product	Model	Open Size	Fold Size	Loading	N.W.	G.W.	Packing Size	
Folding Stretcher	YJK-C-1	220*55*15CM	180*12*15CM	≤159KG	7.6KG	9.8KG	1PC/CTN	192*12*17CM

[Back to the catalog](#)

# Aluminum Alloy Folding Stretcher



YJK-D-1



This product is also known as stretcher, aluminum alloy stretcher, fire stretcher, folding stretcher, rescue stretcher, etc..

The frame part of this product is mainly made of high-strength aluminum alloy, with light weight, small size, easy to carry, safe to use and other characteristics.

This product stretcher surface is made of camouflage oxford leather surface, with pillowcase, so that the patient lying more comfortable. This product has four support feet, in the uneven ground can also rescue the patient, the handle has a telescopic function, convenient to close the storage, reduce the length. This product is equipped with two safety straps to ensure the safety of patients in transit. Can be two folded into the camouflage handbag, saving space and easy to carry.

Mainly used in hospitals, outpatient departments, ambulances, firefighters and troops in the field to transport the sick and wounded or enterprises and institutions, rural health offices, homes for the elderly and tourist attractions equipped for emergency use.

Product	Model	Open Size	Fold Size	Loading	N.W.	G.W.	Packing Size	
Folding Stretcher	YJK-D-1	220*55*15CM	95*20*9CM	≤159KG	8.07KG	8.77KG	1PC/CTN	98*23.5*11CM

[Back to the catalog](#)

# Aluminum Alloy Folding Stretcher



YJK-DL-1



This product is also known as stretcher, aluminum alloy stretcher, fire stretcher, folding stretcher, rescue stretcher, etc..

The frame part of this product is mainly made of high-strength aluminum alloy, with light weight, small volume, easy to carry, safe to use and other characteristics. The stretcher surface is made of camouflage oxford leather surface, which makes the patient more comfortable to lie down. This product has four support feet, the material is cast parts, in the uneven ground can also rescue the patient. The handle has a telescopic function, which is convenient for closing and storing and reducing the length. Equipped with two safety straps to ensure the safety of the patient during transport. This product can be folded and put into camouflage duffel bag, saving space and easy to carry.

Mainly used in hospitals, outpatient departments, ambulances, firefighters and troops in the field to transport the sick and wounded or enterprises and institutions, rural health offices, homes for the elderly and tourist attractions equipped for emergency use.

Product	Model	Open Size	Fold Size	Loading	N.W.	G.W.	Packing Size	
Folding Stretcher	YJK-DL-1	220*55*15CM	50*26*18CM	≤159KG	11.31KG	12.12KG	1PC/CTN	59.5*27*23.5CM

[Back to the catalog](#)



# Aluminum Alloy Folding Stretcher



This product is also known as stretcher, aluminum alloy stretcher, fire stretcher, folding stretcher, rescue stretcher, etc..

The frame part of this product is mainly made of high-strength aluminum alloy, with light weight, small volume, easy to carry, safe to use and other characteristics.

The stretcher surface is made of camouflage oxford leather, which makes the patient more comfortable to lie down. This product is equipped with two safety straps to ensure the safety of patients in transit. It can be folded and put into a camouflage shoulder bag, saving space and making it easy to carry.

Mainly used in hospitals, outpatient departments, ambulances, firefighters and troops in the field to transport the sick and wounded or enterprises and institutions, rural health offices, homes for the elderly and tourist attractions equipped for emergency use.

Product	Model	Open Size	Fold Size	Loading	N.W.	G.W.	Packing Size	
Folding Stretcher	YJK-E-1	185*48*3CM	46*48*14CM	≤159KG	4.86KG	5.53KG	1PC/CTN	54*49.5*14CM

[Back to the catalog](#)

# Aluminum Alloy Folding Stretcher



YJK-EL-1



This product is also known as stretcher, aluminum alloy stretcher, fire stretcher, folding stretcher, rescue stretcher, etc..

The frame part of this product is mainly made of high-strength aluminum alloy, with light weight, small volume, easy to carry, safe to use and other characteristics.

This product stretcher surface is made of camouflage oxford leather surface, so that the patient lying more comfortable. With two wheels at one end and two support feet at the other end, the patient can be transferred by lifting one end of the support feet in case of insufficient manpower. This product is equipped with two safety straps to ensure the safety of the patient during transportation. It can be folded and put into a camouflage shoulder bag, saving space and making it easy to carry.

Mainly used in hospitals, outpatient departments, ambulances, firefighters and troops in the field to transport the sick and wounded or enterprises and institutions, rural health offices, homes for the elderly and tourist attractions equipped for emergency use.

Product	Model	Open Size	Fold Size	Loading	N.W.	G.W.	Packing Size	
Folding Stretcher	YJK-EL-1	185*48*21CM	46*48*14CM	≤159KG	7KG	7.79KG	1PC/CTN	51*49.5*15.3CM

[Back to the catalog](#)

# Aluminum Alloy Folding Stretcher

 YJK-F1-1



This product is also known as stretcher, aluminum alloy stretcher, fire stretcher, folding stretcher, rescue stretcher, etc..

The frame part of this product is mainly made of high-strength aluminum alloy, with light weight, small size, easy to carry, safe to use and other characteristics.

This product stretcher surface is made of orange oxford leather surface, so that the patient lying more comfortable. With four support feet, the patient can be rescued in uneven ground. Equipped with two safety straps to ensure the safety of the patient during transport. The handle is equipped with anti-slip glove to ensure the safety of the patient in the process of transfer. Can be folded and put into the handbag, saving space and easy to carry.

Mainly used in hospitals, outpatient departments, ambulances, firefighters and troops in the field to transport the sick and wounded or enterprises and institutions, rural health offices, homes for the elderly and tourist attractions equipped for emergency use.

Product	Model	Open Size	Fold Size	Loading	N.W.	G.W.	Packing Size	
Folding Stretcher	YJK-F1-1	208*55*13CM	104*17*9CM	≤159KG	4.49KG	5.04KG	1PC/CTN	110*20*11CM

[Back to the catalog](#)

# Aluminum Alloy Folding Stretcher



YJK-F2-1



This product is also known as stretcher, aluminum alloy stretcher, fire stretcher, folding stretcher, rescue stretcher, etc..

The frame part of this product is mainly made of high-strength aluminum alloy, with light weight, small volume, easy to carry, safe to use and other characteristics.

This product stretcher surface is made of military green oxford leather surface, so that the patient lying more comfortable, with four support feet, in the uneven ground can also rescue the patient. The handle is equipped with non-slip glove to ensure the safety of patients in the process of transfer, equipped with two safety straps to ensure the safety of patients in transit, can be folded and put into the suitcase, saving space and convenient to carry.

Mainly used in hospitals, outpatient departments, ambulances, firefighters and troops in the field to transport the sick and wounded or enterprises and institutions, rural health offices, homes for the elderly and tourist attractions equipped for emergency use.

Product	Model	Open Size	Fold Size	Loading	N.W.	G.W.	Packing Size	
Folding Stretcher	YJK-F2-1	214*55*12CM	58*21*14CM	≤159KG	6.9KG	7.5KG	1PC/CTN	68*30*16CM

[Back to the catalog](#)

# Aluminum Alloy Folding Stretcher

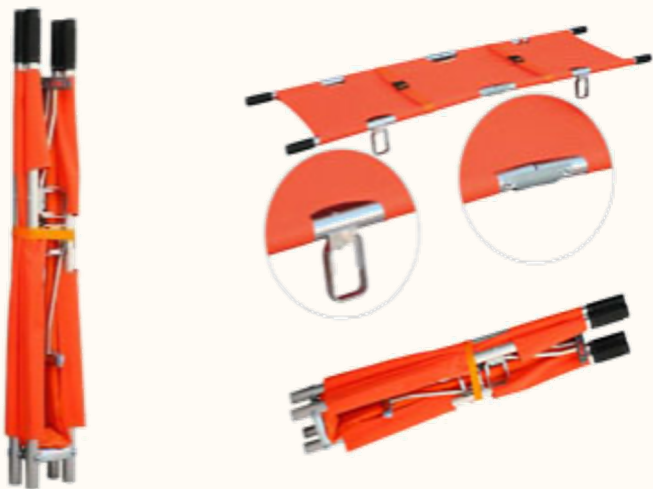

This product is also known as stretcher, aluminum alloy stretcher, fire stretcher, folding stretcher, rescue stretcher, etc..

The frame part of this product is mainly made of high-strength aluminum alloy, with light weight, small volume, easy to carry, safe to use and other characteristics.

This product stretcher surface is made of orange oxford leather surface, making the patient more comfortable to lie down. With four support feet, the patient can be rescued in uneven ground. The handle is equipped with anti-slip glove to ensure the safety of the patient in the process of transfer. Equipped with two safety straps to ensure the safety of the patient during transport. Can be two folded storage, space-saving, easy to carry.

Mainly used in hospitals, outpatient clinics, ambulances, firefighters and troops in the field to transport the sick and wounded or enterprises and institutions, rural health offices, homes for the elderly and tourist attractions equipped for emergency use.

Product	Model	Open Size	Fold Size	Loading	N.W.	G.W.	Packing Size	
Folding Stretcher	YJK-G-1	208*55*15CM	104*17*7.5CM	≤159KG	5KG	11.09KG	2PC/CTN	110.5*19*19CM

[Back to the catalog](#)

# Aluminum Alloy Folding Stretcher



This product is also known as stretcher, aluminum alloy stretcher, fire stretcher, folding stretcher, rescue stretcher, etc..

The frame part of this product is mainly made of high-strength aluminum alloy, which has the characteristics of light weight, small volume, easy to carry and safe to use. The surface of the stretcher is made of orange oxford leather, which makes it more comfortable for the patient to lie down. With four support feet, the patient can be rescued in uneven ground. The handle is equipped with anti-slip glove to ensure the safety of the patient in the process of transfer. Equipped with two safety straps to ensure the safety of the patient during transport. Can be folded and put into the handbag, saving space and convenient to carry.

Mainly used in hospitals, outpatient departments, ambulances, firefighters and troops in the field to transport the sick and wounded or enterprises and institutions, rural health offices, homes for the elderly and tourist attractions equipped for emergency use.

Product	Model	Open Size	Fold Size	Loading	N.W.	G.W.	Packing Size	
Folding Stretcher	YJK-GL-1	215*55*15CM	55*26*17CM	≤159KG	8.37KG	8.9KG	1PC/CTN	66.5*29.5*14CM

[Back to the catalog](#)

# Aluminum Alloy Folding Stretcher



This product is also known as stretcher, aluminum alloy stretcher, body stretcher, folding stretcher, funeral stretcher, etc. .

The frame part of this product is mainly made of high-strength aluminum alloy, with light weight, small size, easy to carry, safe to use and other characteristics. The stretcher surface is made of PU leather, and is equipped with special body bags, with easy to clean, disinfection and other characteristics.

The car is designed with two wheels at one end and two support feet at the other end, so that the body can be transported by lifting one end of the support feet in the case of insufficient manpower. Equipped with two safety straps to ensure the safety of the transport.

This product can be two folded storage, space-saving, easy to carry mainly for hospitals, funeral homes, crematoriums to transport the body used.

Product	Model	Open Size	Fold Size	Loading	N.W.	G.W.	Packing Size	
Folding Stretcher	YJK-H-1	208*53*35.5CM	108*53*12CM	≤159KG	9.3KG	10.8KG	1PC/CTN	110*58*12.5CM

[Back to the catalog](#)

# Aluminum Alloy Folding Stretcher

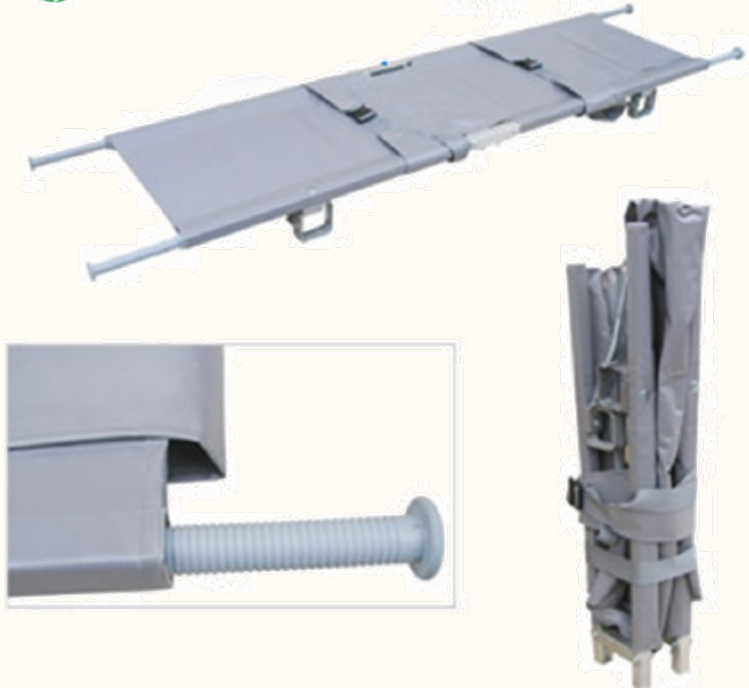

This product is also known as aluminum alloy stretcher, folding stretcher, aluminum alloy folding stretcher.

Made of high-strength aluminum alloy and PVC stretcher surface, it is mainly suitable for narrow aisles and difficult to pass areas. 2 guide wheels facilitate transfer on the ground.

Product	Model	Open Size	Fold Size	Loading	N.W.	G.W.	Packing Size	
Folding Stretcher	YJK-M-1	203*13.5*30CM	92.5*50*7CM	≤159KG	8.3KG	9.16KG	1PC/CTN	103*20.5*14CM

[Back to the catalog](#)



# Aluminum Alloy Folding Stretcher



This product is also known as stretcher, folding stretcher, aluminum alloy stretcher, chair stretcher, etc.

The frame part of this product is mainly made of high-strength aluminum alloy, with light weight, small size, easy to carry, safe to use and other characteristics.

The stretcher surface is made of orange PVC leather surface, which is waterproof and easy to clean. The car is designed with two wheels at one end and two support feet at the other end, so that the patient can be transferred by lifting one end of the support feet in the case of insufficient manpower. The car can be folded into a chair, the two guides are cheap to move on the ground, convenient to transport or transfer patients in narrow aisles or elevators.

This product is equipped with two safety straps to ensure the safety of the patient on the way to the hospital.

Mainly used in hospitals, outpatient departments, ambulances, firefighters and troops in the field to transport the sick and wounded or enterprises and institutions, rural health offices, homes for the elderly and tourist attractions equipped for emergency use.

Product	Model	Open Size	Fold Size	Loading	N.W.	G.W.	Packing Size	
Folding Stretcher	YJK-N-1	188*50*20CM	105*12*54CM	≤159KG	9.73KG	11.23KG	1PC/CTN	110*55*16CM

# Aluminum Alloy Folding Stretcher



YJK-A1-1A



This product is also known as aluminum alloy stretcher, folding stretcher, aluminum alloy folding stretcher, etc..

It is made of high strength aluminum alloy material and Oxford leather surface, it has the characteristics of light weight, small volume, easy to carry, safe to use, etc. It is mainly used in hospitals, sports venues, ambulances and troops in the field to transport the sick and wounded.

Product	Model	Open Size	Fold Size	Loading	N.W.	G.W.	Packing Size	
Folding Stretcher	YJK-A1-1A	190*53*20CM	94*53.5*9.5CM	≤159KG	15.4KG	17KG	1PC/CTN	96*54*10CM

[Back to the catalog](#)

# Aluminum Alloy Folding Stretcher



YJK-A1-1B



This product is also known as aluminum alloy stretcher, folding stretcher, aluminum alloy folding stretcher.

Made of high-strength aluminum alloy material and Oxford leather surface, it has the characteristics of light weight, small size, easy to carry, safe to use, etc. It is mainly used in hospitals, sports venues, ambulances and troops in the field to transport the sick and wounded.

Product	Model	Open Size	Fold Size	Loading	N.W.	G.W.	Packing Size	
Folding Stretcher	YJK-A1-1B	185.5*52*22.2CM	92.4*52*10CM	≤159KG	6KG	6.75KG	1PC/CTN	96*10*53CM

[Back to the catalog](#)

# Aluminum Alloy Folding Stretcher



YJK-A1-1C



This product is also known as aluminum alloy stretcher, folding stretcher, aluminum alloy folding stretcher, etc..

It is made of high strength aluminum alloy material and Oxford leather surface, it has the characteristics of light weight, small volume, easy to carry, safe to use, etc. It is mainly used in hospitals, sports venues, ambulances and troops in the field to transport the sick and wounded.

Product	Model	Open Size	Fold Size	Loading	N.W.	G.W.	Packing Size	
Folding Stretcher	YJK-A1-1C	185*50*21.5CM	91.5*50.5*30CM	≤159KG	8KG	8.5KG	1PC/CTN	96*27*54CM

[Back to the catalog](#)

# Aluminum Alloy Folding Stretcher

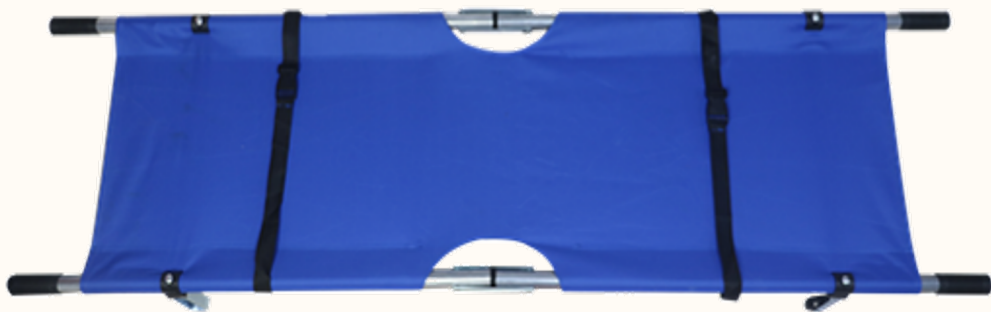

Made of steel tube material and Oxford leather stretcher surface, it has the advantages of light weight, small size, easy to carry, safe to use, etc. It is mainly used in hospitals, sports venues, ambulances and troops to transport the sick and wounded.

Product	Model	Open Size	Fold Size	Loading	N.W.	G.W.	Packing Size	
Folding Stretcher	YJK-HB-1	200*53*18CM	100*30*10CM	≤159KG	5.5KG	6.1KG	1PC/CTN	100*30*10CM

[Back to the catalog](#)

# Aluminum Alloy Ambulance Stretcher



This product is also known as stretcher cart, ambulance stretcher cart, low stretcher cart and so on.

The body part is mainly aluminum alloy structure, with light toughness, easy to disinfect the characteristics of the hospital emergency center for the transfer of the wounded.

The stretcher cart adopts sponge cushion and the backrest can be adjusted to make the patient more comfortable to lie down. The stretcher car adopts a low frame structure, which can be moved on the ground, and can be carried on the ambulance to transfer patients. Both ends of the car are equipped with telescopic handles, which make it easy to lift the stretcher car. The wheel periphery is made of rubber, which is strong and durable. It must be locked with the fixing device on the ambulance after boarding to ensure the safety of the patient during the ambulance journey.

The stretcher cart is equipped with two safety straps to ensure the safety of the patient. The stretcher truck is equipped with an infusion rack.

Product	Model	Open Size	Biggest angle	Loading	N.W.	G.W.	Packing Size	
Ambulance Stretcher	YJK-A-2	190*55*50CM	75°	≤159KG	26KG	32.76KG	1PC/CTN	196.5*63*34.5CM

# Aluminum Alloy Ambulance Stretcher



YJK-A-3



This product is also known as stretcher car, ambulance stretcher car, first aid stretcher, on board stretcher, automatic on board stretcher, rescue car stretcher, rescue stretcher car, etc.

The body part of this product is mainly made of aluminum alloy structure, and the mating parts are made of aluminum alloy die-casting, which has the characteristics of good lightness and toughness and easy disinfection, and is used by hospitals and emergency centers to transfer the wounded.

This stretcher car adopts sponge cushion, the backrest can be adjusted to make the patient more comfortable lying down. Adopting the mechanical structure of folding legs, the folding is controlled by the right-hand handle, and only one ambulance worker is needed to push the patient into the ambulance. The wheel periphery is made of rubber material, which is strong and durable. After boarding, it must be locked with the fixing device on the ambulance to ensure the safety of the patient during the ambulance journey.

This stretcher truck is equipped with two safety straps to ensure the safety of the patient. When the patient is transported to the ward or destination, open the rear fixing lock and slowly pull down from inside the ambulance, the stretcher legs will be automatically lowered.

Product	Model	Open Size	Fold Size	Biggest angle	Loading	N.W.	G.W.	Packing Size	
Ambulance Stretcher	YJK-A-3	190*55*92CM	190*55*26CM	75°	≤159KG	37KG	41.8KG	1PC/CTN	196*63.5*30 CM

[Back to the catalog](#)

# Aluminum Alloy Ambulance Stretcher

 YJK-A2-3



This product is also known as stretcher car, ambulance stretcher car, first aid stretcher, on board stretcher, automatic on board stretcher, rescue car stretcher, rescue stretcher car, etc.

The body part of this product is mainly made of aluminum alloy structure, and the mating parts are made of aluminum alloy die-casting, which has the characteristics of good lightness and toughness and easy disinfection, and is used by hospitals and emergency centers to transfer the wounded.

This stretcher car adopts sponge cushion, the backrest can be adjusted to make the patient more comfortable lying down. Adopting the mechanical structure of folding legs, the folding is controlled by the right-hand handle, and only one ambulance worker is needed to push the patient into the ambulance. The stretcher can be separated and used, the separated stretcher can be carried up and down stairs, narrow roads and other spaces to quickly rescue patients. The wheel periphery is made of rubber, which is strong and durable. After boarding, it must be locked with the fixing device on the ambulance to ensure the safety of the patient during the ambulance journey.

This stretcher truck is equipped with two safety straps to ensure the safety of the patient. When the patient is transported to the ward or destination, open the rear fixing lock and slowly pull down from inside the ambulance, the stretcher legs will be automatically lowered.

Product	Model	Open Size	Fold Size	Biggest angle	Loading	N.W.	G.W.	Packing Size	
Ambulance Stretcher	YJK-A2-3	190*55*92CM	190*55*26CM	75°	≤159KG	43KG	44.7KG	1PC/CTN	196*64*30.5CM

[Back to the catalog](#)



# Aluminum Alloy Ambulance Stretcher

 YJK-A3-3



This product is also known as stretcher car, ambulance stretcher car, first aid stretcher, on board stretcher, automatic on board stretcher, rescue car stretcher, rescue stretcher car, etc.

The body part of this product is mainly made of aluminum alloy structure, and the mating parts are made of aluminum alloy die-casting, which has the characteristics of good lightness and toughness and easy disinfection, and is used by hospitals and emergency centers to transfer the wounded.

This stretcher cart adopts sponge cushion, the backrest can be adjusted to make the patient more comfortable to lie down. The stretcher cart adopts the mechanical structure of folding legs, and the folding is controlled by the right-hand handle, so that only one ambulance worker is needed to push the patient into the ambulance. The stretcher can be separated and used to carry patients up and down stairs, narrow roads and other spaces for quick rescue. Wheel periphery using rubber material, strong and durable. The stretcher cart must be locked with the fixing device on the ambulance after boarding to ensure the safety of the patient during the ambulance journey.

This stretcher truck is equipped with two safety straps to ensure the safety of the patient. When the patient is transported to the ward or destination, open the rear fixing lock and slowly pull down from inside the ambulance, the stretcher legs will be automatically lowered.

Product	Model	Open Size	Fold Size	Biggest angle	Loading	N.W.	G.W.	Packing Size	
Ambulance Stretcher	YJK-A3-3	192*55*98CM	192*55*36CM	75°	≤159KG	39KG	45KG	1PC/CTN	198*62*38 CM

[Back to the catalog](#)

# Aluminum Alloy Ambulance Stretcher



YJK-A5-3



This product is also known as stretcher car, ambulance stretcher car, first aid stretcher, on board stretcher, automatic on board stretcher, rescue car stretcher, rescue stretcher car, etc.

The body part of this product is mainly made of aluminum alloy structure, and the mating parts are made of aluminum alloy die-casting, which has the characteristics of good lightness and toughness and easy disinfection, and is used by hospitals and emergency centers to transfer the wounded.

This stretcher cart adopts sponge cushion, the backrest can be adjusted to make the patient more comfortable to lie down. The stretcher cart adopts the mechanical structure of folding legs, and the folding is controlled by the right-hand handle, so that only one ambulance worker is needed to push the patient into the ambulance. The stretcher can be separated and used to carry patients up and down stairs, narrow roads and other spaces for quick rescue. Wheel periphery using rubber material, strong and durable. After boarding, it must be locked with the fixing device on the ambulance to ensure the safety of the patient during the ambulance journey.

This stretcher truck is equipped with two safety straps to ensure the safety of the patient. When the patient is transported to the ward or destination, open the rear fixing lock and slowly pull down from inside the ambulance, the stretcher legs will be automatically lowered.

Product	Model	Open Size	Fold Size	Biggest angle	Loading	N.W.	G.W.	Packing Size	
Ambulance Stretcher	YJK-A5-3	190*55*92CM	190*55*26CM	75°	≤159KG	39KG	41KG	1PC/CTN	197*63*29.5CM

[Back to the catalog](#)

# Aluminum Alloy Ambulance Stretcher



This product is also known as stretcher car, ambulance stretcher car, low stretcher car, first aid stretcher, on board stretcher, rescue car stretcher, rescue stretcher car, etc..

The body part is mainly aluminum alloy structure, with light toughness, easy to disinfect the characteristics of the hospital emergency center for the transfer of the injured.

The stretcher car adopts sponge cushion, the backrest can be adjusted to make the patient more comfortable lying down. The low frame structure can be used to move on the ground and carry the patient to the ambulance. This stretcher car can not automatically get on the car, the ambulance needs to lift the stretcher car. The wheel periphery is made of rubber, which is strong and durable. After boarding, it must be locked with the fixing device on the ambulance to ensure the safety of the patient during the ambulance journey.

There is storage space underneath the stretcher trolley, which can be equipped with a shovel-type stretcher and a spinal board stretcher. This stretcher cart is equipped with two safety straps to ensure the safety of the patient. The product can be equipped with infusion rack.

Product	Model	Open Size	Biggest angle	Loading	N.W.	G.W.	Packing Size	
Ambulance Stretcher	YJK-B-2	190*55*50CM	75°	≤159KG	29KG	34KG	1PC/CTN	197*63.5*35.5CM

[Back to the catalog](#)

# Aluminum Alloy Ambulance Stretcher



YJK-B-3



This product is also known as stretcher car, ambulance stretcher car, first aid stretcher, on board stretcher, automatic on board stretcher, rescue car stretcher, rescue stretcher car, etc.

The body part of this product is mainly made of aluminum alloy structure, and the mating parts are made of aluminum alloy die-casting, which has the characteristics of good lightness and toughness and easy disinfection, and is used by hospitals and emergency centers to transfer the wounded.

This stretcher car adopts sponge cushion, the backrest can be adjusted to make the patient more comfortable lying down. This stretcher has 3 on the height of the ambulance is adjustable. Adopting the mechanical structure of folding leg, the folding is controlled by the right-hand handle, and only one ambulance worker is needed to push the patient into the ambulance. The wheel periphery is made of rubber material, which is strong and durable. After boarding, it must be locked with the fixing device on the ambulance to ensure the safety of the patient during the ambulance journey.

This stretcher truck is equipped with two safety straps to ensure the safety of the patient. When the patient is transported to the ward or destination, open the rear fixing lock and slowly pull down from inside the ambulance, the stretcher legs will be automatically lowered.

Product	Model	Open Size	Fold Size	Biggest angle	Loading	N.W.	G.W.	Packing Size	
Ambulance Stretcher	YJK-B-3	190*55*92CM	190*55*25CM	75°	≤159KG	40KG	43.8KG	1PC/CTN	195.5*62*27.5CM

# Aluminum Alloy Ambulance Stretcher

 YJK-B2-3



This product is also known as stretcher car, ambulance stretcher car, first aid stretcher, on board stretcher, automatic on board stretcher, rescue car stretcher, rescue stretcher car, etc.

The body part of this product is mainly made of aluminum alloy structure, and the mating parts are made of aluminum alloy die-casting, which has the characteristics of good lightness and toughness and easy disinfection, and is used by hospitals and emergency centers to transfer the wounded.

This stretcher car adopts sponge cushion, the backrest can be adjusted to make the patient more comfortable lying down. This stretcher has 3 on the height of the ambulance is adjustable. Folding leg mechanical structure, only the ambulance staff by the thrust control folding, do not need to be left and right handle to control. Wheel periphery using rubber material, strong and durable. On board must be locked with the ambulance on the fixed device to ensure the safety of the patient during the ambulance journey.

This stretcher truck is equipped with two safety straps to ensure the safety of the patient. When the patient is transported to the ward or destination, open the rear fixing lock and slowly pull down from inside the ambulance, the stretcher legs will be automatically lowered.

Product	Model	Open Size	Fold Size	Biggest angle	Loading	N.W.	G.W.	Packing Size	
Ambulance Stretcher	YJK-B2-3	190*55*92CM	190*55*26.5CM	75°	≤159KG	46KG	47KG	1PC/CTN	195*64*31CM

[Back to the catalog](#)

# Aluminum Alloy Ambulance Stretcher

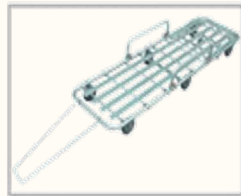

This product is also known as stretcher car, ambulance stretcher car, low stretcher car, first aid stretcher, on board stretcher, rescue car stretcher, rescue stretcher car, etc.

The body part of this product is mainly made of aluminum alloy structure, mating parts aluminum alloy die-casting, with light toughness, easy to disinfect the characteristics of the hospital emergency center for the transfer of the wounded to use.

The stretcher car adopts sponge cushion, the backrest can be adjusted to make the patient lie down more comfortable, the stretcher car adopts a low frame structure, can only move on the ground, can not be lifted to walk. Can not automatically get on the car, the ambulance needs to lift the stretcher car. The wheels of this stretcher cart are made of rubber material, which is strong and durable.

The stretcher cart must be locked with the fixing device on the ambulance after boarding to ensure the safety of the patient during the ambulance journey, and the stretcher cart is equipped with two safety straps to ensure the safety of the patient.

Product	Model	Open Size	Loading	N.W.	G.W.	Packing Size	
Ambulance Stretcher	YJK-C-2	190*62*23CM	≤159KG	18.5KG	20.5KG	1PC/CTN	195*64*22.5CM

# Aluminum Alloy Ambulance Stretcher



YJK-D-3



This product is also known as stretcher car, ambulance stretcher car, first aid stretcher, on board stretcher, automatic on board stretcher, rescue car stretcher, rescue stretcher car, etc.

This stretcher car adopts sponge cushion, the backrest can be adjusted to make the patient more comfortable to lie down. The stretcher adopts a dexterous structure and a mechanical structure with folded legs to achieve a variety of posture shifts, with four adjustable height gears and a right-hand handle to control the folding, requiring only one ambulance crew to push the patient into the ambulance. Wheel periphery using rubber material, strong and durable. After boarding, it must be locked with the fixing device on the ambulance to ensure the safety of the patient during the ambulance journey.

This stretcher truck is equipped with two safety straps to ensure the safety of the patient. When the patient is transported to the ward or destination, open the rear fixation lock and slowly pull down from inside the ambulance, the stretcher legs will be automatically lowered.

Product	Model	Open Size	Fold Size	Biggest angle	Loading	N.W.	G.W.	Packing Size	
Ambulance Stretcher	YJK-D-3	196*55*98CM	196*55*34CM	70°	≤159KG	38.20KG	46.65KG	1PC/CTN	198.5*63*37CM

# Aluminum Alloy Ambulance Stretcher



YJK-D-3 (升级款)



This product is also known as stretcher car, ambulance stretcher car, first aid stretcher, get on stretcher, automatic get on stretcher, rescue car stretcher, rescue stretcher car, etc.

This ambulance stretcher is made of high-strength aluminum alloy, can conveniently achieve a variety of posture change, can adapt to the complex situation of emergency care; only one ambulance personnel to push the car.

The height of the body needs to be adjusted in three gears, can be adjusted to the actual operational requirements into a forward or backward state; head and feet can be adjusted; trolley sponge mattress using PVC material hot-pressing synthesis, the bed side has a block body escort. With the advantages of rust-proof, easy to clean, equipped with front and rear fixing device, locked with the bottom of the car after getting on the car.

Product	Model	Open Size	Fold Size	Biggest angle	Loading	N.W.	G.W.	Packing Size	
Ambulance Stretcher	YJK-D-3	198*54*94CM	198*54*35CM	75°	≤159KG	38KG	44KG	1PC/CTN	199*58*35 CM

[Back to the catalog](#)



# Aluminum Alloy Ambulance Stretcher

 YJK-D2-3



This product is also known as stretcher car, ambulance stretcher car, first aid stretcher, on board stretcher, automatic on board stretcher, rescue car stretcher, rescue stretcher car, etc.

This stretcher car adopts sponge cushion, the backrest can be adjusted to make the patient more comfortable to lie down. The stretcher adopts a dexterous structure and a mechanical structure with folded legs to achieve a variety of posture shifts, with four adjustable height gears, controlled folding by the right-hand handle, and only one ambulance worker is needed to push the patient into the ambulance. Can be separated from the use of the stretcher can be carried up and down stairs, narrow roads and other spaces in order to quickly rescue patients. Wheel periphery using rubber material, strong and durable. After boarding, it must be locked with the fixing device on the ambulance to ensure the safety of the patient during the ambulance journey.

This stretcher truck is equipped with two safety straps to ensure the safety of the patient. When transporting the patient to the ward or destination, open the rear fixing lock and slowly from the ambulance.

Product	Model	Open Size	Fold Size	Biggest angle	Loading	N.W.	G.W.	Packing Size	
Ambulance Stretcher	YJK-D2-3	196*55*98CM	196*55*38CM	75°	≤159KG	42KG	52.12KG	1PC/CTN	201*63.5*37 CM

[Back to the catalog](#)

# Aluminum Alloy Ambulance Stretcher



This product is also known as stretcher cart, chair stretcher cart, ambulance stretcher cart, etc.

The body part of this product is mainly made of aluminum alloy structure, and the mating parts are aluminum alloy die-casting, which has the characteristics of good lightness and toughness and easy disinfection, and is used by hospitals and emergency centers to transfer the wounded.

The stretcher cart adopts four sponge cushions and the backrest can be adjusted to make the patient more comfortable to lie down. Adopting the mechanical structure of folding leg, the folding is controlled by the right-hand handle. The wheel periphery is made of rubber material, which is strong and durable. After boarding, it must be locked with the fixing device on the ambulance to ensure the safety of the patient during the ambulance journey.

This stretcher vehicle is equipped with two safety straps to ensure the safety of the patient. It can be folded into a chair type, and the angle of the chair can be adjusted in five gears. The product is suitable for transferring patients in limited space, such as hospital elevators, ambulances, aircraft and urban road ambulance.

Product	Model	Open Size	Fold Size	Biggest angle	Loadin g	N.W.	G.W.	Packing Size	
Ambulance Stretcher	YJK-E-3	196*55*86CM	196*55*25CM	85°	≤159KG	34KG	38.73KG	1PC/CTN	198*63.5*27CM

# Aluminum Alloy Ambulance Stretcher



YJK-E-3 (升级款)



This product is also known as stretcher cart, chair stretcher cart, ambulance stretcher cart, etc.

The body part of this product is mainly made of aluminum alloy structure, and the mating parts are made of aluminum alloy die-casting, which has the characteristics of good lightness and toughness and easy disinfection, and is used by hospitals and emergency centers for transferring the injured.

This trolley is produced by high-quality aluminum alloy, the bed surface is upholstered with sponge, the bed side has a block body guard, rust-proof, easy to clean features, light weight, easy to use, in narrow stairways, elevators, and other narrow space, can be quickly folded into a wheelchair use.

Product	Model	Open Size	Fold Size	Biggest angle	Loading	N.W.	G.W.	Packing Size	
Ambulance Stretcher	YJK-E-3	196*60*88CM	196*60*27CM	75°	≤159KG	32KG	38KG	1PC/CTN	199*60*28CM

[Back to the catalog](#)

# Aluminum Alloy Ambulance Stretcher

 YJK-G-3



This product is also known as stretcher car, ambulance stretcher car, first aid stretcher, on board stretcher, rescue car stretcher, rescue stretcher car, etc..

The body part of this product is mainly made of aluminum alloy structure, mating parts aluminum alloy die-casting, with light toughness, easy to disinfect the characteristics of the hospital emergency center for the transfer of the wounded to use.

The stretcher car adopts sponge cushion, the backrest can be adjusted to make the patient more comfortable lying down. There are high, medium and low 3 height gears to adjust. Two ambulance personnel are needed to lift the patient into the ambulance. The wheel periphery is made of rubber material, which is strong and durable.

This stretcher car must be locked with the fixing device on the ambulance after getting on board, to ensure the safety of the patient during the ambulance journey, equipped with two safety straps to ensure the safety of the patient.

Product	Model	Open Size	Median Size	Fold Size	Loading	N.W.	G.W.	Packing Size	
Ambulance Stretcher	YJK-G-3	190*55*88CM	190*55*72CM	190*55*40CM	≤159KG	35KG	41KG	1PC/CTN	195*62*42CM

[Back to the catalog](#)

# Scoop Stretcher



YJK-A-4



This product is also known as separation stretcher, shovel stretcher, aluminum alloy shovel stretcher, etc.

Made of high-strength aluminum alloy material, four plates: foldable, detachable and expandable. Foldable design, portable and easy to stack, greatly reducing the space occupied, conducive to large-scale applications.

The detachable design adopts a separate rigid structure to transfer fractures and seriously injured patients. Both ends are equipped with a clutch device, which can be separated into two parts left and right side switch easier to operate, providing better protection for the injured. In the case of not moving the patient, quickly shovel the patient into or extract the stretcher from under the patient's body.

Retractable design, the length of the stretcher can be adjusted according to the length of the person, a total of 3 gears. Narrow frame structure at one end of the stretcher (feet). Suitable for patients of any size and height.

The product is equipped with safety straps to ensure the safety of the patient. The spade stretcher can be used together with the head immobilizer.

Product	Model	Open Size	Fold Size	Loading	N.W.	G.W.	Packing Size	
Scoop Stretcher	YJK-A-4	208×44×7CM	166.5×44×7CM	≤159KG	7.13KG	8.25KG	1PC/CTN	172×45.5×7.5CM

[Back to the catalog](#)

# Scoop Stretcher

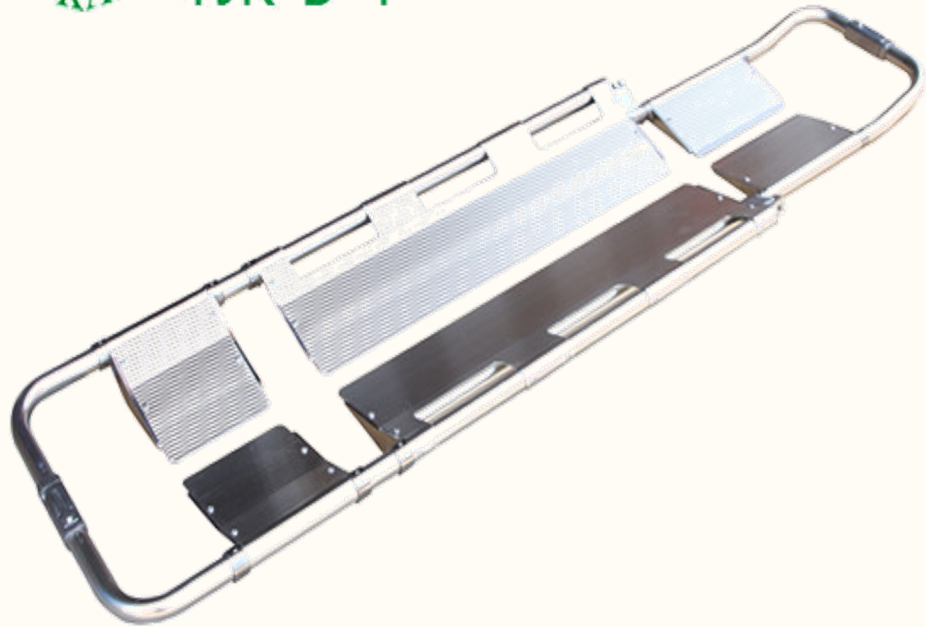

This product is also known as separation stretcher, shovel stretcher, aluminum alloy shovel stretcher, etc.

Made of high-strength aluminum alloy material, six plates: foldable, detachable and expandable. Foldable design, portable and easy to stack, greatly reducing the space occupied, conducive to large-scale applications.

The detachable design adopts a separate rigid structure to transfer fractures and seriously injured patients. Both ends are equipped with a clutch device, which can be separated into two parts left and right side switch easier to operate, providing better protection for the injured. In the case of not moving the patient, quickly shovel the patient into or extract the stretcher from under the patient's body.

Retractable design, the length of the stretcher can be adjusted according to the length of the person, a total of 3 gears. Narrow frame structure at one end of the stretcher (feet). Suitable for patients of any size and height.

The product is equipped with safety straps to ensure the safety of the patient.

Product	Model	Open Size	Fold Size	Loading	N.W.	G.W.	Packing Size	
Scoop Stretcher	YJK-B-4	210×44×6CM	120×44×9CM	≤159KG	7.56KG	8.89KG	1PC/CTN	170.5×46×7CM

# Scoop Stretcher



YJK-C-4

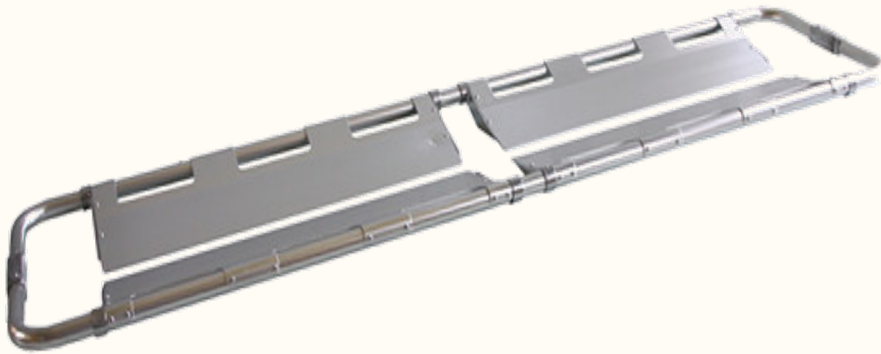

This product is also known as separation stretcher, shovel stretcher, aluminum alloy shovel stretcher, etc.

Made of high strength aluminum alloy material, four plates: detachable, non-retractable, non-foldable. Detachable design, using the rigid structure of the separation type, transferring fractures and serious injuries and patients. Both ends are equipped with a clutch device, which can be separated into two parts left and right side switch easier to operate and provide better protection for the injured. Without moving the patient, quickly shovel the patient into or pull out the stretcher from under the patient's body.

The length of this model is fixed, four plate combination, suitable for patients of all body types and heights.

The product is equipped with safety straps to ensure the safety of the patient. The spade stretcher can be used together with the head fixer.

Product	Model	Open Size	Loading	N.W.	G.W.	Packing Size	
Scoop Stretcher	YJK-C-4	185×43×6CM	≤159KG	8.4KG	9.93KG	1PC/CTN	187×46.5×6.5CM

[Back to the catalog](#)

# Plastic spade stretcher



YJK-D-4



This product is also known as separation stretcher, shovel stretcher, PE plastic stretcher, plastic stretcher and so on.

Made of high-strength engineering plastic, the thermal material does not make the patient feel too hot or too cold, and the surface is easy to clean to prevent liquid penetration. X-ray and MRI permeable.

Foldable design, portable and easy to stack, greatly reducing the space occupied, conducive to large-scale applications. Detachable design, with clutching devices at both ends, the stretcher can be separated into two parts, so that the patient can be quickly shoveled in or pulled out from under the patient's body without moving the patient. The groove at the head end is suitable for maintaining the patient's spinal alignment.

Retractable design, the length of the stretcher can be adjusted according to the length of the person, a total of 3 gears, suitable for any size and height of the patient.

The product is equipped with safety straps to ensure the safety of the patient. The spade stretcher can be used together with the head immobilizer.

Product	Model	Open Size	Fold Size	Loading	N.W.	G.W.	Packing Size	
Plastic spade stretcher	YJK-D-4	162×45×7CM	116.5×44.8×7.5CM	≤159KG	9.03KG	10.89KG	1PC/CTN	165×47.5×8.5CM

[Back to the catalog](#)



# Plastic spade stretcher



YJK-D2-4

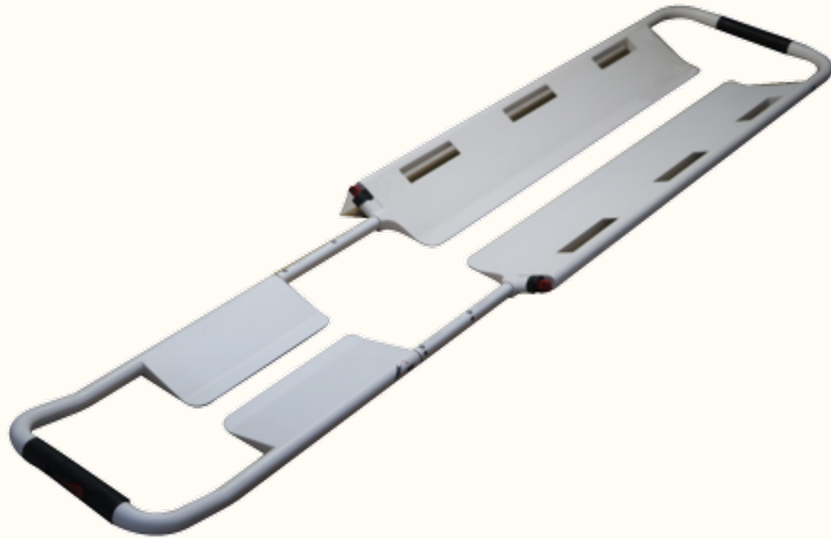

This product is also known as separation stretcher, shovel type stretcher.

Foldable design, portable and easy to stack, greatly reducing the space occupied, conducive to large-scale applications. Detachable design, using a separate rigid structure, transferring fractures and serious injuries and patients. Both ends are equipped with a clutch device, which can be separated into two parts left and right side switch easier to operate, providing better protection for the injured.

Without moving the patient, quickly shovel the patient into or pull out the stretcher from under the patient's body.

The product is equipped with safety straps to ensure the safety of the patient.

Product	Model	Open Size	Fold Size	Loading	N.W.	G.W.	Packing Size	
Plastic spade stretcher	YJK-D2-4	172.3×43.6×7.3CM	119.5×43.6×7.3CM	≤159KG	5.5KG	6.5KG	1PC/CTN	175×45×8CM

[Back to the catalog](#)

# Basket Stretcher



YJK-A-6



This stretcher is also known as basket stretcher, basket stretcher, air hoist stretcher, marine stretcher, helicopter stretcher, etc.

It is made of non-toxic and non-polluting ABS material, which is light and resistant to pressure, easy to clean, and has the function of fireproof, wear-resisting and anti-erosion. The edge of the aluminum alloy tube is reinforced, and there are many arc-shaped sleek handles, which are convenient for many people to lift during use; the stretcher has metal buckles on both sides, and can be used with nylon buckles.

The structure of this stretcher focuses on the wide range of first aid, flexibility and special features, such as rugged mountainous areas, air or sea rescue. The sturdy and durable frame and the simple and reliable device allow the operator to take first aid measures safely and quickly. The hooks can be connected to the hooks on the aircraft. To achieve wilderness rescue.

The stretcher is equipped with adjustable foot anchors, which can be adjusted according to the height of the casualty.

The product is equipped with safety straps to effectively fix the casualty, and the snap design is more convenient to use. This product is equipped with a sling, which can be lifted from a height.

Product	Model	Open Size	Loading	N.W.	G.W.	Packing Size	
Basket Stretcher	YJK-A-6	219×64×18CM	≤159KG	18.7KG	19.64KG	1PC/CTN	223×67.5×21CM

# Basket Stretcher



This stretcher is also known as basket stretcher, basket stretcher, air hoist stretcher, marine stretcher, helicopter stretcher, etc.

It is made of non-toxic and non-polluting ABS material, which is light and resistant to pressure, easy to clean, and has the function of fireproof, wear-resisting and anti-erosion. The edge of the aluminum alloy tube is reinforced, and there are many arc-shaped sleek handles, which are convenient for many people to lift during use; the stretcher has metal buckles on both sides, and can be used with nylon buckles.

The structure of this stretcher focuses on the wide range of first aid, flexibility and special features, such as rugged mountainous areas, air or sea rescue. The sturdy and durable frame and the simple and reliable device allow the operator to take first aid measures safely and quickly.

The stretcher is equipped with adjustable foot anchors, which can be adjusted according to the height of the casualty.

The detachable design, portable and easy to stack, greatly reduces the space occupied and facilitates first aid applications. The product is equipped with safety straps to effectively fix the casualty, and the snap design is more convenient to use. This product is equipped with a sling, suspension hook can be connected with the hook on the aircraft. Realize field rescue.

Product	Model	Open Size	Fold Size	Loading	N.W.	G.W.	Packing Size	
Basket Stretcher	YJK-B-6	219×64×18CM	130×67×29CM	≤159KG	18.97KG	21.69KG	1PC/CTN	130×67.5×25.5CM

# Basket Stretcher



This stretcher is also known as basket stretcher, hanging basket stretcher, air hoist stretcher, marine stretcher, helicopter stretcher, etc.

It is made of non-toxic and non-polluting released materials, fireproof and resistant to abrasion and erosion, made of stainless steel tubes and nets, will not cause additional harm to the patient, is stronger than ordinary stretchers, can be used with board stretchers, easy to transport and store, and easy to clean. The stretcher is equipped with metal buckles on both sides, and can be used with nylon ties.

Mainly suitable for rugged mountainous areas, air or sea rescue. The frame is strong and durable, and the simple and reliable device allows the operator to take first aid measures safely and quickly. The hook can be connected with the hook on the aircraft to achieve field rescue.

The product is equipped with nylon straps to effectively fix the casualty, and the carabiner design is more convenient to use.

Product	Model	Open Size	Loading	N.W.	G.W.	Packing Size	
Basket Stretcher	YJK-C-6	212×67×25CM	≤159KG	19.5KG	20.5KG	1PC/CTN	215×70×28CM

# Basket Stretcher



This stretcher is also known as basket stretcher, hanging basket stretcher, air hoist stretcher, marine stretcher, helicopter stretcher, etc.

Made of stainless steel tube and net, it is fireproof and resistant to abrasion and erosion, and will not cause additional harm to the patient. The stretcher has metal buckles on both sides and can be used with nylon ties.

The structure of this stretcher is designed for the wide range of first aid, flexibility and special features, such as rugged mountainous areas, air or sea rescue. The sturdy and durable frame and the simple and reliable device allow the operator to take first aid measures safely and quickly.

The stretcher is equipped with adjustable foot anchors, which can be adjusted according to the height of the casualty. The detachable design, portable and easy to stack, greatly reduces the space occupied and facilitates first aid applications.

The product is equipped with safety straps to effectively fix the casualty, and the snap design is more convenient to use. This product is equipped with a sling, suspension hook can be connected with the hook on the aircraft. Realize field rescue.

Product	Model	Open Size	Fold Size	Loading	N.W.	G.W.	Packing Size	
Basket Stretcher	YJK-D-6	212×67×25CM	115×67×28CM	≤159KG	20KG	22.5KG	1PC/CTN	130×65×25CM

# Stair Stretcher



YJK-A-5



This product is also known as upstairs stretcher, wheelchair stretcher, up and down stairs stretcher, stairs stretcher, etc.

It is made of aluminum alloy with light and flexible structure. It has a light weight, small size, easy to carry, safe to use, easy to clean and disinfect. Other materials are made of oxford cloth fabric.

Foldable structure is easy to carry, used for rescuing fracture patients up and down the stairs. The product is equipped with a wide insurance belt to ensure the safety of the patient in the transfer process. The stretcher is equipped with two wheels to facilitate movement on the ground. The stretcher is equipped with a reinforced handle at the back end, which can bear more weight.

This product requires 2 people to operate at the same time. When carrying a patient up and down the stairs, the front lifting lever is pulled out and the back handle is opened to hold up and carry.

Product	Model	Open Size	Loading	N.W.	G.W.	Packing Size	
Stair Stretcher	YJK-A-5	92×52.2×91.5CM	≤159KG	10.09KG	11.58KG	1PC/CTN	97.3×55×19CM

[Back to the catalog](#)

# Stair Stretcher



YJK-B-5



This product is also known as upstairs stretcher, wheelchair stretcher, up and down stairs stretcher, stairs stretcher, etc.

It is made of aluminum alloy with light and flexible structure. It has a light weight, small size, easy to carry, safe to use, easy to clean and disinfect. Other materials are made of oxford cloth fabric.

Foldable structure is easy to carry, used for rescuing fracture patients up and down the stairs. The product is equipped with a wide insurance belt to ensure the safety of the patient in the transfer process.

The stretcher is equipped with 2 small wheels in front and 2 large wheels at the back to facilitate movement on the ground. The back end of the stretcher is equipped with a reinforced handle, which can bear more weight.

This product requires 2 people to operate at the same time, when carrying a patient up and down the stairs, the front lifting lever is pulled out and the back handle is opened to hold up and carry.

Product	Model	Open Size	Fold Size	Loading	N.W.	G.W.	Packing Size	
Stair Stretcher	YJK-B-5	90×51×91CM	90×17×59CM	≤159KG	9.5KG	11KG	1PC/CTN	96×16.5×55CM

[Back to the catalog](#)

# Stair Stretcher



This product is also known as upstairs stretcher, wheelchair stretcher, up and down stairs stretcher, stairs stretcher, etc.

It is made of aluminum alloy with light and flexible structure. It has light weight, small size, easy to carry, safe to use, easy to clean and disinfect. Other materials are used polyethylene plastic sheet.

Foldable structure is easy to carry, used for rescuing fracture patients up and down the stairs. The product is equipped with a wide insurance belt to ensure the safety of the patient during the transfer process. The stretcher is equipped with four wheels to facilitate movement on the ground. The stretcher is equipped with a reinforced handle at the back end, which can bear more weight, and a total of six handles to adapt to different heights going up and down the stairs.

This product requires 2 people to operate at the same time, when lifting and transporting patients up and down stairs, the front lifting lever is pulled out and the back handle is opened to hold up and carry.

Product	Model	Open Size	Fold Size	Loading	N.W.	G.W.	Packing Size	
Stair Stretcher	YJK-C-5	90×51×91CM	90×17×59CM	≤159KG	13.98KG	16.29KG	1PC/CTN	100×62.5×20CM

[Back to the catalog](#)



# Stair Stretcher

 YJK-D-5



This product is also known as upstairs stretcher, wheelchair stretcher, up and down stairs stretcher, stairs stretcher, etc.

It is made of aluminum alloy with light and flexible structure. It has a light weight, small size, easy to carry, safe to use, easy to clean and disinfect. Other materials are made of oxford cloth fabric. Foldable structure is easy to carry, used for rescuing fracture patients up and down the stairs. The product is equipped with a wide insurance belt to ensure the safety of patients in the transfer process.

The stretcher is equipped with four large wheels to facilitate the movement on the ground, with stirrups, safety is more secure. The stretcher is equipped with a reinforced handle at the back end, which can bear more weight.

This product requires 2 people to operate at the same time, when lifting and transporting patients up and down the stairs, the front lifting lever is pulled out and the back handle is opened to hold up and carry.

Product	Model	Open Size	Fold Size	Loading	N.W.	G.W.	Packing Size	
Stair Stretcher	YJK-D-5	99.5×99.5×48CM	99.5×48×29CM	≤159KG	10.02KG	12.85KG	1PC/CTN	102×55.5×31CM

[Back to the catalog](#)

# Stair Stretcher



YJK-E-5



This product is also known as upstairs stretcher, wheelchair stretcher, up and down stairs stretcher, stairs stretcher, stair climbing chair.

It adopts aluminum alloy material and track, with light weight, small size, easy to carry, safe to use, easy to clean, foldable structure is easy to carry, used for rescuing fracture patients up and down the stairs.

This product adopts the reinforced anti-slip track design, downstairs only one person can operate. When going upstairs, 2 people need to operate at the same time, the front lifting lever is pulled out, and the rear handle is opened to hold up for carrying. The stair stretcher is equipped with 4 wheels, convenient for moving on the ground, with stirrup frame, safety is more secure.

This product is comfortable soft cushion, foam curved handle, with two pairs of seat belts to ensure the safety of patients in the transfer process.

Product	Model	Open Size	Fold Size	Loading	N.W.	G.W.	Packing Size	
Stair Stretcher	YJK-E-5	163×138×51CM	113×54×33CM	≤159KG	19KG	32.4KG	1PC/CTN	117.5×58×32CM

[Back to the catalog](#)

# Stair Stretcher

 YJK-F-5



This product is also known as wheelchair stretcher, stair stretcher, stair stretcher, stair climbing chair, etc..

It adopts aluminum alloy material and track, with light weight, small size, easy to carry, safe to use, easy to clean, foldable structure is easy to carry, used for rescuing fracture patients up and down the stairs.

This stretcher is mainly used in high-rise buildings to transfer patients down the stairs, only one person can operate; this product can only be operated downstairs, not upstairs. The unique crawler structure makes it convenient and safe for the stretcher to go down the stairs. The stretcher is equipped with a total of four wheels, which is convenient for moving on the ground.

The stretcher is equipped with two pairs of safety belts to ensure the safety of the patient during the transfer process.

Product	Model	Open Size	Fold Size	Loading	N.W.	G.W.	Packing Size	
Stair Stretcher	YJK-F-5	78×52×134CM	78×52×22CM	≤159KG	9KG	10KG	1PC/CTN	80×54×24CM

[Back to the catalog](#)

# Stair Stretcher

 YJK-E2-5



This product is also known as upstairs stretcher, wheelchair stretcher, up and down stairs stretcher, stairs stretcher, stair climbing chair, electric stairs stretcher, electric stair climbing car, etc..

This product is made of aluminum alloy, motor, track, etc. The product can be folded, easy to carry and safe to use, easy to clean.

This product has no restrictions on the height and width of the stair steps, the general family stairs are available (folded into the trunk)! The front wheels are PU universal wheels, rear wheels with brakes, in the process of use, can stay on the stairs, will not slide! Higher safety. At the same time, there is a power display on the product, you can observe the use of power in a timely manner, ready to charge.

This product uses reinforced anti-skid track type design, one key electric control, up and down the stairs only need someone to assist in the operation, effortless. In case of emergency without electricity, only 2 people are needed to operate up and down the stairs. When going up and down the stairs, 2 people need to operate at the same time, the front lifting lever is pulled out, and the rear handle is opened and held up for carrying.

Product	Model	Open Size	Fold Size	Loading	N.W.	G.W.	Packing Size	
Stair Stretcher	YJK-E2-5	105×50×155CM	105×50×28CM	≤159KG	34KG	44.3KG	1PC/CTN	117.5×58×32CM

[Back to the catalog](#)



YJK-E3-5

# Stair Stretcher



This product is also known as upstairs stretcher, wheelchair stretcher, up and down stairs stretcher, stairs stretcher, stair climbing chair, electric stairs stretcher, electric stair climbing car, etc..

This product is made of aluminum alloy, motor, track, etc. The product can be folded, easy to carry and safe to use, easy to clean.

Product	Model	Open Size	Fold Size	Loading	N.W.	G.W.	Packing Size	
Stair Stretcher	YJK-E3-5	108×64×103CM	108×64×30CM	≤159KG	45KG	60KG	1PC/CTN	113×70×36CM

[Back to the catalog](#)

# Multifunctional Rescue Stretcher



Made of special composite plastic, it can be bent and deformed for use, small size, light weight, easy to carry, and wide range of applications.

The stretcher is equipped with extra rope straps on the side to facilitate the implementation of air rescue. Strong nylon straps to effectively fix the casualty, the buckle is equipped with adjustable size. Nylon strap handle with plastic rubber band, not strangling hands.

Can be used for fire emergency rescue, deep well and narrow space rescue, ground general rescue, high-altitude rescue, chemical accident scene rescue, etc. Can be lifted horizontally or vertically.

Product	Model	Open Size	Temperature Resistance	N.W.	G.W.	Packing Size	
Multifunctional Rescue Stretcher	YJK -F5	252×87×0.5cm	-20°C— 45°C	10.4	12.3kg	1PC/CTN	91.5×36×36.5CM



YJK-E-7

# Vacuum Mattress Stretcher



This product is also known as vacuum stretcher, negative pressure stretcher, limb fixation airbag, torso stretcher.

The torso fixation airbag is made of high wear-resistant TPU material seamlessly fused to reduce the patient's weight and heat loss effectively. It is lined with polymer foam particles and equipped with a special pump.

After wrapping the torso/limb fixation airbag on the part of the body that needs to be fixed, the air inside the torso/limb fixation airbag is pumped away by the special pump, so that the torso/limb fixation airbag matches the shape of the body and fits tightly together to protect the injured part and avoid secondary injuries.

Torso fixation airbag can realize various operation methods such as passenger, sea and air transportation at the same time. Small size, light quality, easy to carry, strong protection, sturdy and durable.

X-ray imaging and magnetic resonance examination can be carried out, and it is quick and easy to use and can be operated by non-professionals.

Product	Model	Open Size	Fold Size	Loading	N.W.	G.W.	Packing Size	
Vacuum Mattress Stretcher	YJK-E-7	210×105×6CM	90×57×26cm	≤159kg	6.2KG	7.8KG	1PC/CTN	88.5×28×48CM

[Back to the catalog](#)

# Vacuum Mattress Stretcher



YJK-E-7-2



This product is also known as vacuum stretcher, negative pressure stretcher, limb fixation airbag, torso stretcher, etc.

Torso fixation airbag is made of high wear-resisting TPU material seamlessly fused to reduce the patient's weight and heat loss effectively. It is lined with polymer foam particles and equipped with a special pump.

After wrapping the torso/limb fixation airbag on the part of the body that needs to be fixed, the air inside the torso/limb fixation airbag is pumped away by the special pump, so that the torso/limb fixation airbag matches the shape of the body and fits tightly together to protect the injured part and avoid secondary injuries.

Product	Model	Open Size	Fold Size	Loading	N.W.	G.W.	Packing Size	
Vacuum Mattress Stretcher	YJK-E-7-2	195×95cm	94×39×34cm	≤159kg	4.6KG	5.46KG	1PC/CTN	48×38×45cm

[Back to the catalog](#)





# Thanks for watching

---

**Feel free to add any theme you want in the header. Feel free to add any theme you want in the header.**